



File Name: Commercial amana microwave manual.pdf

Size: 1480 KB

Type: PDF, ePub, eBook

Category: Book

Uploaded: 20 May 2019, 21:50 PM

Rating: 4.6/5 from 685 votes.

Download Now!

Please check the box below to proceed.



I'm not a robot



reCAPTCHA
Privacy - Terms

Book Descriptions:

Commercial amana microwave manual



Our chat service hours are Monday Friday from 8 a.m. 8 p.m. EST. This should be visible once you slide it open. This should be visible once you flip over the cooktop. This should be visible once you open the door. This should be visible once you open the lid. Please visit acpsolutions.com or call 319 3688120 for more info about these products. Limited warranty is provided by the manufacturer. Please call 888 8422440 for more info about these products. Limited warranty is provided by the manufacturer. Please call 888 8422440 for more info about these products. We're here to help. Looking forward to being pen pals! Please try again later. For more information about our privacy practices and a list of our affiliated brands, please read our Privacy Notice. Please check your inbox, and if you can't find it, check your spam folder to make sure it didn't end up there. Please also check your spam folder. If the oven changes ownership, this manual must accompany oven. Product information is located on oven serial plate. Record the following information Amana also recommends contacting an authorized Amana servicer if service is required after warranty expires. Connect only to properly EARTHED outlet. See "EARTHING INSTRUCTIONS" on page 5. Do not use corrosive chemicals or vapors in this equipment. This type of oven is specifically designed to heat, cook, or dry food. It is not designed for industrial or laboratory use. Special tools are required to service equipment. Contact nearest authorized service facility for examination, repair, or adjustment. It is important not to defeat or tamper with the safety interlocks. It is particularly important that the oven door close properly and that there is no damage to the Carefully attend oven when paper, plastic, or other combustible materials are placed inside the oven to facilitate cooking. DO NOT leave paper products, cooking utensils, or food in the cavity when not in use. <http://nv-tel.ru/public/european-automotive-repair-manuals.xml>

- **amana commercial microwave manual, amana commercial microwave manual rcs10ts, amana commercial microwave manual hdc182, amana commercial microwave manual clean filter, amana commercial microwave rc17s2 manual, amana commercial microwave rms10ts manual, amana commercial microwave service manual, amana commercial microwave rcs10dse manual, amana commercial microwave oven manual, amana commercial microwave user manual, commercial amana microwave manual, amana commercial microwave manual, amana commercial microwave manual**

rms10ts, amana commercial microwave rcs10ts manual.



Visible bubbling or boiling when the container is removed from the microwave oven is not always present. Fat could overheat and be hazardous to handle. Pressure may build up and erupt. Pierce yolk with fork or knife before cooking. When skin is pierced, steam escapes evenly. Popping time varies depending on oven wattage. Do not continue to heat after popping has stopped. Popcorn will scorch or burn. Do not leave oven unattended. Most cooking thermometers contain mercury and may cause an electrical arc, malfunction, or damage to oven. Heated synthetics could melt and cause paper to ignite. Food or liquid could expand quickly and cause container or bag to break. Pierce or open container or bag before heating. Record all inspections and repairs for future use. Infrequent cleaning could adversely affect the life of the appliance and possibly result in a hazardous situation. You can be assured that you will have fast shipping to anywhere in Canada. We recognize that restaurant owners do not have time to worry about their delivery followups. Our customer service is excellent and professional. We promise on all of our deliveries to be quick and worry free. Can you imagine the effect on your customers. Make sure your equipment is doing its job; come see us at Vortex and put your concerns to rest. Our variety of configurations and options can be designed to best suit your commercial kitchen layout and your budget. You cannot risk such a catastrophe. Choose the proper commercial dishwashing equipment and supplies, and you and your staff will be able to clean up your dishes in a quick and effective manner. It is imperative to have clean and sanitized tableware for your customers. With pots, pans, inserts, and all your kitchen accessories, your workspace can become crowded very quickly. <http://accesoriosalmayor.com/images/userfiles/european-bus-simulator-2012-manual.xml>



The proper storage of all items is done most efficiently by our selection of Storage and Stainless shelving, chrome or epoxy racks and of course, no kitchen is complete without the versatile work table. All food service businesses need to keep their food properly stored, separated, and ready for easy transport. Whether you need baking supplies, pizza pans and bags, bartending supplies, or food storage inserts, see us at Vortex Restaurant Equipment for those ohsoimportant kitchen pieces. We know your time is valuable so base on your business type, you can choose the latest and greatest variety of Restaurant Supplies to keep your customers happy and your employees working efficiently. Reduces prep time, labor and food waste while providing consistent results. Your rating Competitive prices, fast shipping across Canada. Please enable JavaScript. Morbi eleifend consetetur pharetra. Nam non dolor vel purus mattis aliquet. Please wait. Please wait. Choose My Store Please click here to sign in or create an account. Add a Review 0 out of 5 stars Listed below are several companies that may meet your needs in helping to assist you in getting the equipment you need for your business. Please contact our National Order Office to speak with one of our professional associates who can assist you in working with your financing partner. Charges are calculated using our distribution center in Ohio as the point of origin. Columbus, OH 43215 Sign up here instead. You should have JavaScript enabled in your browser to utilize the functionality of the website Parts Town and 3Wire have joined forces and teamed up with IPC, combining the team you know with the largest inventory in the industry and cuttingedge technology to give you the absolute best experience. Things look a little different, thats true, but you are indeed in the right place. Hi there, welcome to Parts Town.

Parts Town and 3Wire have joined forces and teamed up with NDCP, combining the team you know with the largest inventory in the industry and cuttingedge technology to give you the absolute best experience. Parts Town and 3Wire have joined forces and teamed up with SMS, combining the team you know with the largest inventory in the industry and cuttingedge technology to give you the absolute best experience. Hi there! RSCS and Parts Town have joined forces, combining the team you know with the largest inventory in the industry and cuttingedge technology to give you the absolute best experience. Parts Town and 3Wire Foodservice have joined forces. Now youll work with the great team you know, while having access to the largest inventory in the industry and cuttingedge technology. Lets go! Continue to Parts Town What You Can Expect Always Genuine OEM The Most InStock Parts on the Planet Breakthrough Innovations Exceptional Customer Experience Same Day Shipping Ready to get started. Lets go! Continue to Parts Town Looking for beverage equipment parts. Marmon Link is the new home for genuine OEM parts for the Marmon family of equipment manufacturers. Find beverage dispense parts and accessories, as well as parts for Cornelius, Prince Castle, Silver King, Angelo Po, and Saber King units. Continue to Marmon Link

Please try again. Please try again later. Please try again later. No worries, it's really easy. No need to remember another username, you will now use your email address. Its listed below. Once logged in you can view pricing and order these parts. OK Please try again. Always Available free backorder shipping applies to UPS Ground shipments only. Excludes international orders, UPS Freight orders, consolidated shipments, factory drop ship orders, and ship complete orders. Program details subject to change at any time. No need to type it all again. That just makes things WAY easier.

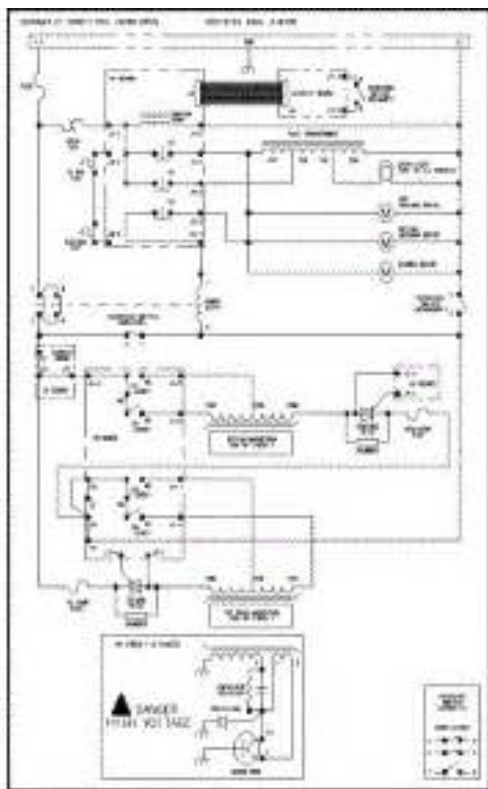

<http://www.bowdata.net/evenement/boss-506ua-manual>

Plus, you'll be able to access any discounts or contract pricing that may be available to you. That's important. The real question is, why wouldn't you log in Everybody loves cookies. Okay, they're not those kind of cookies, but they're still great. Please try again. Please try again. In order to navigate out of this carousel please use your heading shortcut key to navigate to the next or previous heading. Page 1 of 1 Start over Page 1 of 1 In order to navigate out of this carousel please use your heading shortcut key to navigate to the next or previous heading. Register a free business account Please try your search again later. To calculate the overall star rating and percentage breakdown by star, we don't use a simple average. Instead, our system considers things like how recent a review is and if the reviewer bought the item on Amazon. It also analyzes reviews to verify trustworthiness. Continue to Marmon Link Please try again later. You'll find all the replacement parts, components and accessories to keep your Amana microwave or cooking equipment safe and efficient. By choosing OEM, you not only ensure safety and reliability, but you also keep your unit protected under the manufacturer's warranty. Choose from a wide variety of assemblies, shields, motors and other MenuMaster microwave parts designed to fit and function with your specific unit. Amana was founded in 1934 and continues to make equipment that can easily warm, reheat, steam or broil food. Their top products include Parts Town has the most in-stock Amana commercial microwave parts on the planet for a wide variety of models. We even offer same-day shipping on in-stock parts until 9 PM ET Monday-Friday and all online orders until 4 PM ET Saturday, so your kitchen never stops cooking. Parts Town also has in-depth Amana manuals and resources available online. Look up

everything from service instructions to troubleshooting tips all in one easy place. Need help finding exact replacement parts for your model.

<http://darrellpugsley.com/images/captiveworks-cw-600s-manual-1.pdf>



We also have specific Amana parts lists and Menumaster commercial microwave manuals that tell you which components and accessories are compatible with your equipment. Please try again later. No worries, it's really easy. No need to remember another username, you will now use your email address. Its listed below. Once logged in you can view pricing and order these parts. OK Please try again. We commit to carrying additional stock of these critical items to help ensure they are always available when you need them. No need to type it all again. I would like a price quote with delivery on the Amana Commercial Digital Microwave 1.2 Cft CountertopRCS10TS. Will you get back to me with a quote on this item, delivered to my location Limited 3 year Warranty Amana Commercial highspeed cooking products help thousands of food service establishments cook smarter and faster. Designed to help operators reduce prep time, increase efficiency and improve overall food quality, these highperforming ovens have become critical, energyefficient equipment in todays busy foodservice environments. As the only Americanbased commercial microwave manufacturer, ACP has the ability to customize product and provide unique solutions for every food service need. Applications Pizza restaurants Casual dining Clubs Deli Power Output 1000 watts of power. Five power levels for consistent, delicious results for frozen, refrigerated and fresh foods from the freezer to table in minutes. Easy to Use Up to 100 programmable menu items simplifies cooking and ensures consistent results. Four stage cooking option for easy onetouch cooking. Multiple quantity pad calculates the proper cooking times for multiple portions. User friendly touch controls are easy to use. Time entry option for added flexibility. Braille touch pads are ADA compliant. Stackable to save valuable counter space. Easy to Maintain Stainless steel exterior and interior for easy cleaning and a professional look.

<http://www.britishcomics.com/images/captiveworks-700s-user-manual.pdf>



Nonremovable air filter protects oven components. Constructed to withstand the foodservice environment. Limited 3 year warranty. UL and ETL Listed. Specifications Model RCS10TS RMS10TS UPC Code 728028020724 Configuration Countertop Control System Touch Programmable Control Pads 10 Settings Programmable 100 Max. Touch pad shall include Braille for ADA compliance. Cooking timer shall be 60 minute, countdown style with a time entry option and an adjustable end of cycle audible signal. LED display shall be a backlit. There shall be 5 power levels, including defrost and 4 cooking stages. Microwave output shall be 1000 watts distributed by one magnetron with a rotating top antenna to provide superior even heating throughout the cavity. Durable door shall have a tempered glass window and a grab and go handle with a 90 deg plus opening for easy access. An interior light shall facilitate monitoring without opening the door. Interior ceramic shelf shall be sealed and recessed on oven bottom to reduce plate to shelf edge impact. Oven shall have a stainless steel interior and exterior and be stackable to save counter and shelf space. Front air filter shall be permanently affixed to the front of the oven and have a clean filter reminder. Microwave oven shall comply with standards set by the U.S Department of Health and Human Services, UL for safety and ETL for sanitation. Warranty Limited 3 year warranty Year 1 parts, labor, and travel are covered. Years 2 3 magnetron tube part only is covered. Amana Wattage Comparison RCS10TS QuickStart Guide RCS10TS Spec RCS10TS Manual Frequently Asked Questions Microwave Usage Is it normal that my fan runs and the light remains on after the cook cycle has completed. Many operators are not familiar with hearing cooling fans because they often aren't as noticeable in domestic microwaves. Commercial microwaves typically run hotter due to a higher wattage output and more frequent usage.

This creates the need for the fan to continue running to cool oven components, even after the cycle is completed. All ACP, Inc. microwave ovens have a cooling fan that is designed to run after the oven door is opened for approximately one minute. When you hear the fan running after completing a cook cycle or when you open the door, it is normal. There is not a problem with the oven. The microwave light will remain on during this time. The clean filter indicator is on. What does this mean. The clean filter indicator comes on automatically as a reminder to clean the air filter. The indicator will come on every 7 days and will stay on for 24 hours. All HDC, RC, ACE and AXP products have removable air filters. Simply remove and rinse with warm, soapy water. The air filter does not remove on RCS and RFS product. To clean your filter, simply use a damp rag to wipe across the filter, freeing any debris. The filter is located directly below the microwave door. How do you remove a burn smell from the cavity. To remove the smell, place 2 cups of water mixed with 2 Tbs of lime juice and 1 Tbs of molasses in a microwave safe container and bring to a boil in the oven for at least 5 minutes. Leave baking soda in the oven overnight. What are microwave power levels. Power

levels represent the percentage of time the magnetron stays on. The magnetron will cycle on and off, which can allow time for the heat to penetrate food without over cooking. What is the purpose of 4 cook stages. Multiple cook stages allow you to fine tune your cook cycles to the unique needs of your menu items. For example, you can defrost and cook under the same program setting without any operator interaction. This helps ensure you get consistent, quality results with minimal effort. Why cant you use metal cookware in a microwave. Metal reflects microwave energy and will prevent food from cooking properly. Additionally, reflection of energy may create arcing, which can damage microwave components.

<http://www.yoursurveysurveyors.co.uk/wp-content/plugins/formcraft/file-upload/server/content/files/16283bdad64b0f--bt-paperjet-55-manual.pdf>

How do you defrost with food using a commercial microwave. Not all commercial microwaves have the defrost button commonly found on a residential microwave. To defrost, simply use 20% microwave power level. What steps should be taken for proper maintenance of a microwave. For best performance and to improve the longevity of the microwave, clean it regularly with a mild dish detergent and damp wash cloth. Ensure that you clean the air filter, located underneath the microwave door, by wiping it down and freeing any obstructions. If your air filter is removable, remove it and clean it with soap and water. Why are there no turntables in commercial microwaves. Commercial microwaves differ from residential microwaves in that they use a stirrer system to evenly distribute the microwave energy throughout the cavity. Rather than move the food around with a turntable, the energy is moved, which offers more even cooking without the hassles of a turntable. Can I stack two microwaves on top of each other. All of our microwaves and combination ovens are stackable with the exception of the RC30. No additional legs or stacking kits are necessary. If stacking ovens of different sizes, always stack the lighter oven on top of the heavier oven. Can I plug my microwave into a GFCI outlet. Plugging your microwave into a GFCI outlet is not recommended. The microwave may trigger the reset, which can disrupt the flow of your operation. Buying and Servicing Which commercial microwave oven is best for my business. To determine which oven is best for you, use the correct oven for you questionnaire on our website. Are there any special precautions I should take when unpacking my microwave. When removing the microwave from the box and placing it in its final location, do not lift or carry the oven by the handle. Be careful not to remove the film covering the oven light located inside the cavity. Where can I buy parts for my ACP, Inc. Visit the ACP Service Website for a list of ACP, Inc.

cysasdo.com/geektic/files/briggs-and-stratton-quantum-engine-manual.pdf

Your warranty covers manufacturer component failures. Check your warranty certificate for information on your specific product. If you no longer have your certificate, call ComServ at 8664262621. My microwave stopped working. What should I do First, check that your oven is plugged in and your outlets are working. Check your circuit breaker to ensure it is not tripped. Try unplugging the microwave for at least 5 minutes to reset the oven. Microwave Safety Is it safe to run a microwave without food in the cavity. Running a microwave with no load can cause serious damage to electrical components. When food is placed in the oven, microwave energy generated by the magnetron is absorbed by the food. When no food is in the oven, there is nothing to absorb the energy. The energy bounces around the cavity and is channeled back through the waveguide. This can cause arcing, fire and may burn out the magnetron. Can microwave energy escape from the oven. The slotted choke door seal prevents microwave energy from escaping the oven cavity. It is not dangerous to stand close to a running microwave. Is microwave energy harmful. No, microwaves are actually less harmful than sunlight. On the electromagnetic spectrum, microwaves are closest to radio waves. All microwave ovens are thoroughly tested in the factory for microwave leakage before shipment. Do microwaves interfere with pacemakers. Today pacemakers are fitted with electromagnetic shields to prevent any interference. Being near a microwave with a pacemaker is

now perfectly safe. Cooking Time 6000 min Power Levels 5 Please verify before purchasing Cant decide what you need. Were here to help! Give our friendly customer support a call 4847858679 Limited 3 year Warranty Amana Commercial highspeed cooking products help thousands of food service establishments cook smarter and faster. Being near a microwave with a pacemaker is now perfectly safe.

Cooking Time 6000 min Power Levels 5 Please verify before purchasing Cant decide what you need. Were here to help! Give our friendly customer support a call 4847858679 All Rights Reserved. Restauranttory.com and logos are sole property of respected owners. Have Comments or Questions. Contact Us! Review our Privacy Policy.

<https://www.interactivelearnings.com/forum/selenium-using-c/topic/16551/boss-506ua-manual>